



Russell Hobbs



LUXE COLD PRESS SLOW JUICER

2 YEAR WARRANTY

RHSJ100

RHSJ100_IB_FA_140119 Part No. T22-9000711

INSTRUCTIONS & WARRANTY

IMPORTANT SAFEGUARDS

When using this appliance, basic safety precautions should always be followed, including the following:

Read all instructions before, and follow whilst using this appliance.



1. To protect against electrical hazards, do not immerse the power cord, plug or appliance in water or other liquid.
2. Do not use this appliance near bathtubs, showers, basins or other vessels containing water.
3. Do not use outdoors.
4. Do not let cord hang over edge of table surfaces or counter.
5. Do not let cord contact hot surface, including the stove.
6. This appliance is not intended for use by persons (including children) with reduced physical, sensory or mental capabilities, or lack of experience and knowledge, unless they have been given supervision or instruction concerning use of the appliance by a person responsible for their safety.
7. Do not put your fingers or other objects into the juicer opening while it is in operation. If food becomes lodged in opening, use the food pusher or another piece of fruit or vegetable to push it down. When this method is not possible, turn the motor off, remove the plug from the wall power outlet and disassemble juicer to remove the remaining food.
8. Do not push the food into the chute with anything other than the food pusher when the appliance is connected to a power source.
9. Always make sure the juicer jar lid is locked securely in place before motor is turned on. Do not unfasten the locking plate while juicer is in operation.
10. Care should be taken when handling sharp components, including the grinding head, during assembly, disassembly and when cleaning.
11. Do not touch moving parts.
12. Ensure the switch is in the "OFF" position after each use of the juicer. Make sure the motor stops completely before disassembling.
13. Keep the appliance and the power cord away from the edge of tables or countertops and out of reach of children and persons with reduced physical, sensory and mental capabilities.
14. Always turn off and unplug the appliance from the power outlet when not in use, before fitting or removing attachments and before cleaning the appliance.
15. The use of filter attachments/accessories not recommended by the appliance manufacturer may cause injuries or damage to the appliance and void warranty.
16. This appliance is NOT a toy. Children should be supervised to ensure they do NOT play with this appliance.
17. Always follow the instructions when using this appliance.
18. Always clean the appliance after use.
19. Please ensure all detachable parts are completely dry after cleaning before re-assembling the appliance for next use.
20. If the power cord is damaged, it must be replaced by the manufacturer or similarly qualified person in order to avoid hazard.
21. Do not operate this appliance with a damaged cord/plug or after the appliance has malfunctioned, or been dropped or damaged in any manner. Contact Customer Service for examination, adjustment, repair or replacement.
22. Care must be taken when handling filter attachments and when removing or fitting attachments into the juicer.

23. To disconnect, ensure the appliance switch is set to Off, turn off wall power outlet, then grasp and pull the plug from the wall outlet. Never pull by the cord.
24. Misuse may cause injury.
25. Do not attempt to defeat any safety interlock mechanisms.
26. Do not leave the appliance unattended when in use.
27. Do not use the appliance for other than its intended purpose.
28. Do not use on an inclined plane or unstable surface.
29. For added safety, electrical appliances should be connected to a power outlet that is protected by a residual current device (RCD), also often referred to as a 'Safety Switch'. Your switchboard may already incorporate an RCD. If unsure, call an electrician for verification and fitting if necessary.

This appliance is intended to be used in household and similar applications such as:

- Staff kitchen areas in shops, offices and other working environments;
- Farm houses;
- By clients in hotels, motels, and other residential type environments;
- Bed & breakfast type environments.

SAVE THESE INSTRUCTIONS

Congratulations on the purchase of your new Russell Hobbs Luxe Cold Press Slow Juicer. Each unit is manufactured to ensure safety and reliability. **Before using the appliance for the first time, please read this instruction booklet carefully and keep it for future reference.** Pass it on if you pass on the product.

When using this appliance, basic safety precautions should always be followed.

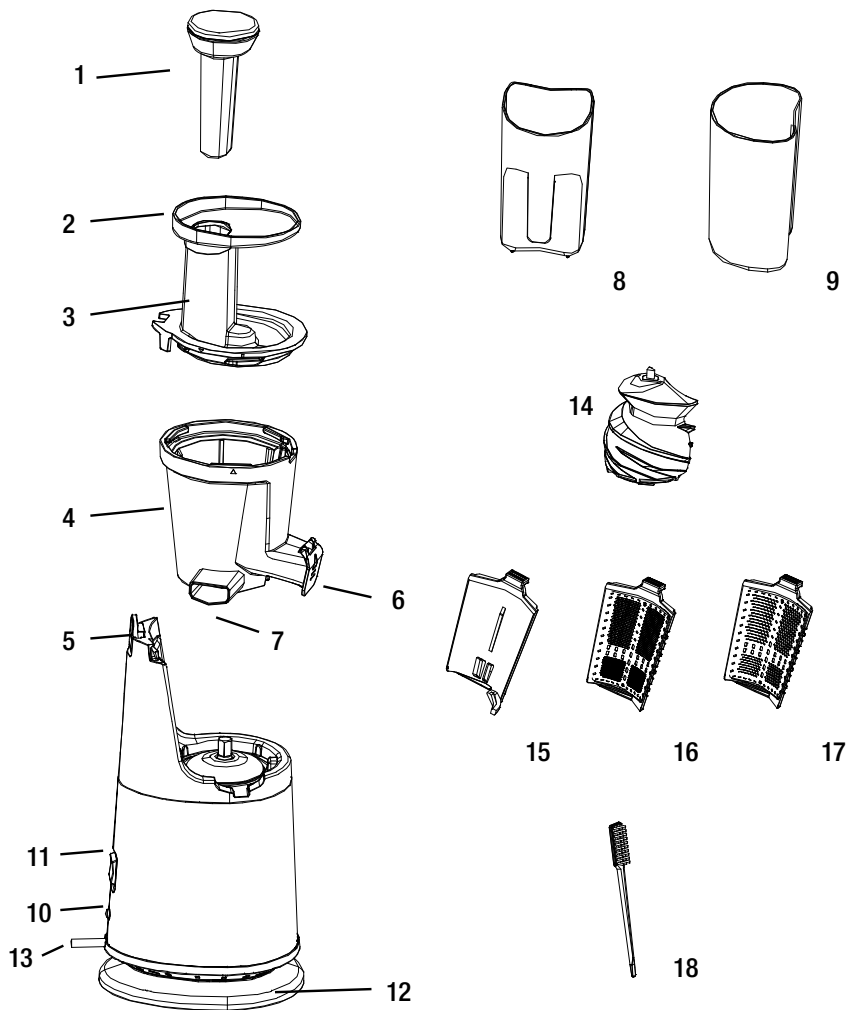

- | | | |
|----------------------------|----------------------|-----------------------------|
| 1. Food pusher | 7. Residue outlet | 13. Power cord |
| 2. Feed chute top | 8. Juice container | 14. Grinding head |
| 3. Jar lid | 9. Residue container | 15. Frozen fruit attachment |
| 4. Jar | 10. Reset button | 16. Fine filter |
| 5. Locking plate | 11. Switch | 17. Coarse filter |
| 6. Juice outlet with cover | 12. Base | 18. Cleaning brush |

GENERAL USE

BEFORE FIRST USE

- Carefully remove all packaging material, any stickers, and the plastic protector from over the power plug.
- As some parts may be packed separately, check to ensure all items have been unpacked before disposing of the packaging.
- Remove and save the instruction booklet.
- All parts need to be thoroughly cleaned before being used for the first time (see 'Care and Maintenance').

IMPORTANT GUIDELINES HOW TO USE THE JUICER

1. Follow the below instructions when preparing different types of foods for slow juicing:
 - Foods with hard fibre should be cut into 3-5cm slices in length and 1.5-2cm in thickness.
 - Leafy vegetables and foods with long & hard fibre (such as celery, wild celery herb and collard greens etc), should have their stems cut of into slices of 3-5cm in length.
 - Do not place any seeds and cores of fruits (such as peach, plum, mango or apricot) into the juicer to avoid any malfunction.
 - Fruits and vegetables which have a hard skin should be peeled before being put into the juicer for processing.
 - Do not put any ice into the slow juicer.
 - Do not process any ingredients with high vegetable or animal oil to avoid the degradation and damage of the grinding head.
 - Hard fibre foods, such as coconut or sugarcane should be pre-soaked before processing them in the slow juicer.
 - It is not recommended to process hard fruits or vegetables rich in fibre and starch.
 - Remove any peels and pits from foods such as oranges, lemons, grapefruits and melons.
2. Follow the below instructions when using the frozen fruit attachment:
 - The slow juicer is not suitable for ice crushing.
 - Do not process any hard frozen fruits. Make sure to semi-defrost the foods before processing them.
 - Do not push the food into the chute with excessive force.
 - The frozen fruit attachment cannot be replaced by the coarse filter or the fine filter when in use.
3. Do not overload the slow juicer with too many ingredients at a time and cut the foods to a size that fits into the feed chute.
4. After use, allow the appliance to cool down between 5-10 minutes. Once the appliance has completely cooled down, you may disassemble and start cleaning the parts (see "Care & Maintenance" p.9).

NOTE: If you try to disassemble the appliance when still hot, you may notice that the parts do not come off easily.

ASSEMBLING THE SLOW JUICER

1. Before putting the jar in position, please check if the inner plug is placed in the residue outlet (see Fig.2). Place the jar downwards on the motor unit (see Fig.1).

NOTE: The jar needs to be assembled properly, otherwise the appliance will not operate.

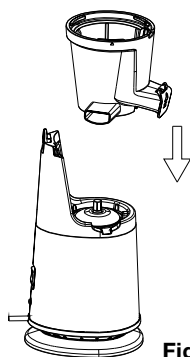

Fig. 1

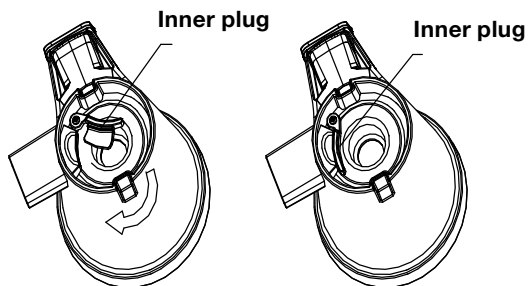

Fig. 2

2. There are three filter attachments including a fine filter, coarse filter and frozen fruit attachment. Select your preferred filter and insert it into the jar. Once in place put the grinding head into the jar (see Fig 3).

NOTE: The grinding head needs to slot into the axis of the motor. Slowly turn the grinding head clockwise until it falls into place.

NOTE: The filter attachments cannot be interchanged while the product is in use. To change the filter, the grinding head and jar lid need to be disassembled.

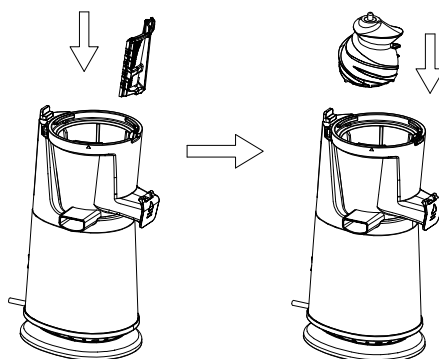

Fig. 3

TYPES OF FILTERS

FINE FILTER: Use the fine filter for juice with less pulp.

COARSE FILTER: Use the coarse filter for juice with more pulp, or to do jams.

FROZEN FRUIT ATTACHMENT: Use this attachment to process semi-defrosted fruits to frozen treats, such as fruit based ice creams, thicker purees or frozen fruit drinks.

- Put the jar lid downwards on the jar and then align the symbol “▼” on the jar lid with the symbol “▲” on the jar. Then rotate the jar lid clockwise until the symbol “▲” on the jar aligns with the symbol “I” on the jar lid (see Fig.4). Press the locking plate upwards to lock the jar lid into position. Every part needs to be assembled correctly, otherwise the appliance will not operate. Place the food pusher into the chute.

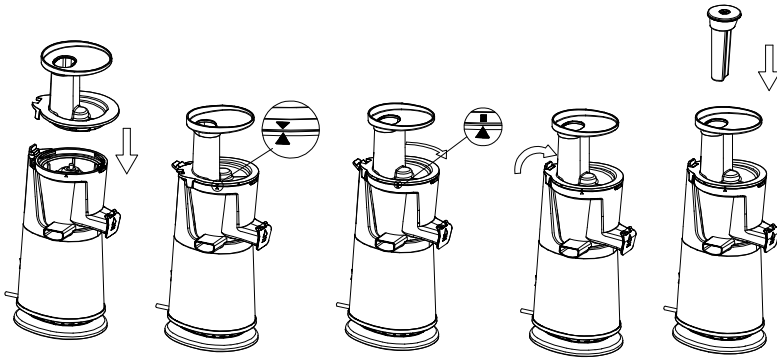

Fig. 4

- Place the juice container under the juice outlet and residue container below the residue outlet (see Fig.5). The slow juicer is now ready to operate.

NOTE: The juice outlet has a spout cover. Ensure the cover is open when operating the juicer.

NOTE: The slow juicer motor base is heavy. When moving or carrying the appliance please hold and carry by the motor unit instead of the jar lid.

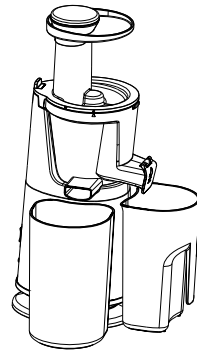

Fig. 5

OPERATING YOUR JUICER

- Before attaching the power cord into the power outlet, make sure the unit power switch is in the “O” position. The switch has three settings:
 - “I” indicates “ON”: press the power switch to “I” position to start the motor;
 - “O” indicates “OFF”: press the power switch to “O” position to turn the juicer off;
 - “S” means reverse rotation: this setting can be used to reverse the grinder rotating and unclog any food stuck in the jar.
- Make sure the juice container and the residue container are placed in position.
- Cut fruits and vegetables into small pieces.
- Place the prepared fruits or vegetables into the feed chute and gently push the food down using the food pusher.
- Connect the appliance to the power outlet, and then press the power switch to the “ON” position.

NOTE: Please refer to "IMPORANT GUIDELINES HOW TO USE THE JUICER" and prepare the food accordingly.

Caution: Do not turn the power switch from "I" to "↵" or from "↵" to "I" directly at any time during operation. If required, firstly press the power switch to "O" position to stop the appliance and then turn the power switch from "I" to "↵" or from "↵" to "I".

Caution: Do not operate the unit without food to avoid damaging the grinding assembly (includes grinding head and filter).

Caution: Do not put any objects other than recommended foods into the feed chute while product is in use.

6. When the juice container is full turn the power switch to the "O" position and empty the juice container and residue container before continuing.

NOTE: The max operation time is 15 minutes. After 15 minutes, let the unit rest for 30 minutes before starting a new juicing cycle.

NOTE: Do not insert too much food at a time.

NOTE: The slow juicer has a safety interlock switch. If any parts loosen or disconnect during operation, the unit will switch off.

7. Enjoy the fresh juice in time for best taste. Any leftover juice can be stored in the refrigerator.

TROUBLESHOOTING:

If the juicer stops operating, it may have tripped the reset button "" located above the power cord. The reset button may trip if the unit has become clogged with food or if it has overheated from being run too long.

1. Press the power switch to the "O" (Off) position and then let the unit cool down for 30 minutes.
2. Once cooled, press the reset button "" on the back of the unit and then press the power switch to the "↵" (reverse) position in short bursts to clear any clogged foods.
3. Switch the power to the "I" (On) position and the unit should run freely.

NOTE: If the unit does not run freely, switch Off immediately and remove the plug from the wall power outlet. Dismantle and clean out the grinding mechanism.

CARE AND MAINTENANCE

1. Unplug the appliance and wait until it has completely cooled down before disassembling and cleaning.
2. Remove the food pusher, then unclip the locking plate outwards to release the jar lid. Turn the jar lid anti-clockwise to remove it.
3. Lift the jar upwards to remove it from the motor unit.

NOTE: It is recommended to disassemble the jar, filter and grinding head over a kitchen sink.

4. Detach the filter attachment and grinding head from the jar. For easy disassembly of the grinder head, push the grinder axis upwards (see Fig.6). Ensure that one hand holds the jar and the other holds the grinder head.
5. Empty the residue container, and then clean the jar lid, grinding head, filter, jar and residue container under running water. When cleaning the filter, only brush the concave surface of the strainer under running water with the cleaning brush.

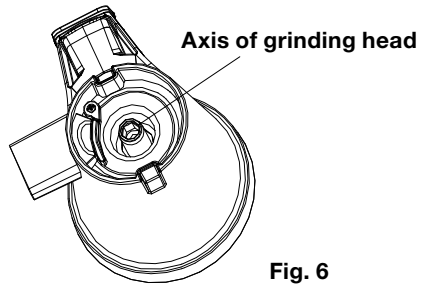

Fig. 6

Caution: Filter attachments are sharp, so handle carefully during cleaning.

Caution: Never use abrasive cleansers or scouring pads to clean the appliance, as they may damage the surfaces.

6. To clean the residue outlet, pull the inner plug out of the outlet. This will make it easy to access the outlet with the cleaning brush (see Fig. 2).
7. Wipe the outside of motor unit with a damp cloth. Never immerse the motor unit in water.
8. Dry and assemble all parts well and then store the appliance in a dry place.

STORING

- Make sure that the appliance is thoroughly dry.
- Never wrap the cord tightly around the appliance, keep it loosely coiled.
- The juice container can be stored in the residue container.

Spectrum Brands Australia Pty Ltd

Locked Bag 3004 Braeside
Victoria 3195 Australia

Customer Service in Australia

TollFree: 1800 623 118
Email: info@spectrumbrands.com.au
Website: www.spectrumbrands.com.au

Spectrum Brands New Zealand Ltd

PO Box 9817 Newmarket
Auckland 1149 New Zealand

Customer Service in New Zealand

TollFree: 0800 736 776
Email: service@spectrumbrands.co.nz
Website: www.spectrumbrands.co.nz

Spectrum Brands Australia Pty Ltd and Spectrum Brands New Zealand Ltd Warranty Against Defects

In this warranty:

Australian Consumer Law means the Australian consumer law set out in Schedule 2 to the Competition and Consumer Act 2010;

CGA means the New Zealand Consumer Guarantees Act 1993;

Goods means the product or equipment which was accompanied by this warranty and purchased in Australia or New Zealand, as the case may be;

Manufacturer, We or us means:

1. for Goods purchased in Australia, Spectrum Brands Australia Pty Ltd ABN, 78 007 070 573;
or
2. for Goods purchased in New Zealand, Spectrum Brands New Zealand Ltd, as the case may be, contact details as set out at the end of this warranty;

Supplier means the authorised distributor or retailer of the Goods that sold you the Goods in Australia or in New Zealand; and

You means you, the original end-user purchaser of the Goods.

1. Our goods come with guarantees that cannot be excluded under the Australian Consumer Law, or the CGA. You are entitled to a replacement or refund for a major failure and compensation for any other reasonably foreseeable loss or damage. You are also entitled to have the goods repaired or replaced if the goods fail to be of acceptable quality and the failure does not amount to a major failure.
2. The benefits provided by this Warranty are in addition to all other rights and remedies in respect of the Goods which the consumer has under either the Australian Consumer Law or the CGA. The original purchaser of the Goods is provided with the following Warranty subject to the Warranty Conditions:
3. We warrant the Goods for all parts defective in workmanship or materials for a period of 2 years (**Warranty Period**) from the date of purchase.

If the Goods prove defective within the Warranty Period by reason of improper workmanship or material, we may, at our own discretion, repair or replace the Goods without charge.

Warranty Conditions

4. The Goods must be used in accordance with the manufacturer's instructions. This Warranty does not apply should the defect in or failure of the Goods be attributable to misuse, abuse, accident or non-observance of manufacturer's instructions on the part of the user. As far as the law permits, the manufacturer does not accept liability for any direct or consequential loss, damage or other expense caused by or arising out of any failure to use the Goods in accordance with the manufacturer's instructions.
5. Exhaustible components (such as batteries, filters and brushes) of the Goods are included under this Warranty only where there is a defect in workmanship or materials used.
6. The warranty granted under clause 3 is limited to repair or replacement only.
7. Any parts of the Goods replaced during repairs or any product replaced remain the property of the manufacturer. In the event of the Goods being replaced during the Warranty Period, the warranty on the replacement Goods will expire on the same date as for the Warranty Period on the original Goods which are replaced.
8. In order to claim under the warranty granted under clause 3 you must:
 - (a) Retain this warranty with your receipt/proof of purchase; and
 - (b) Return the Goods to us at the relevant address or to the Supplier by prepaid freight within the Warranty Period accompanied with (i) the legible and unmodified original proof of purchase, which clearly indicates the name and address of the Supplier, the date and place of purchase, the product name or other product serial number and (ii) this warranty.
9. This warranty is immediately void if:
 - (a) Any serial number or appliance plate is removed or defaced;
 - (b) The Goods have been serviced or otherwise repaired by a person not authorised to do so by us or where non approved replaced parts are used.
10. The Goods are designed for domestic use only. The Goods must be connected to the electrical voltage requirements as specified in the ratings label located on the Goods.
11. This warranty does not cover the cost of claiming under the warranty or transport of the Goods to and from the Supplier or us.
12. This warranty is only valid and enforceable in Australia against Spectrum Brands Australia Pty Ltd and in New Zealand against Spectrum Brands New Zealand Ltd.

Contact us or the Supplier for further details.

Register your product online

If you live in Australia please visit: www.spectrumbrands.com.au/warranty

If you live in New Zealand Please visit: www.spectrumbrands.co.nz/warranty

Registration of your warranty is not compulsory, it gives us a record of your purchase AND entitles you to receive these benefits: Product information; Hints and tips; Recipes and news; Information on special price offers and promotions.

Any questions? Please contact Customer Service for advice.



www.russellhobbs.com.au

www.russellhobbs.co.nz