



Russell Hobbs



TURBO RICE COOKER

2 YEAR WARRANTY

RHRC20

INSTRUCTIONS & WARRANTY

IMPORTANT SAFEGUARDS

When using this appliance, basic safety precautions should always be followed, including the following:

1. Read all instructions before, and follow whilst using this appliance.
2. Do not touch hot surfaces. Use handles or knobs.
3. To avoid burns, stay clear of the steam vent during cooking.
4. Do not leave the plastic rice paddle, rice measuring cup or any other utensils in or on the unit while it is in use.
5. When hot, this appliance contains hot water and steam. Lift off lid carefully to avoid scalding, and allow water to drip into rice cooker.
6. To protect against electric shock DO NOT spill liquids over the controls or immerse cord, plug or heating body in water or any other liquid. 
7. WARNING: Do not spill liquids on the power inlet connector.
8. Do not use this appliance near bathtubs, showers, basins or other vessels containing water.
9. Do not use outdoors.
10. This product is not intended for use by persons (including children) with reduced physical, sensory or mental capabilities, or lack of experience and knowledge, unless they have been given supervision or instruction concerning use of the product by a person responsible for their safety.
11. This appliance is not a toy. Children must be supervised to ensure they do not play with this appliance.
12. Cleaning or user maintenance shall not be carried out by children without the supervision of a person responsible for their safety.
13. Always switch off and disconnect this appliance from the wall power outlet when not in use and before cleaning.
14. To disconnect, turn off the wall power outlet, then grasp and remove the plug. Never pull by the cord.
15. Do not operate the appliance with a damaged cord or plug or after the appliance has malfunctioned, or has been dropped or damaged in any manner. Contact customer service for replacement, examination, repair or adjustment.
16. Do not use the inner pot if dented, bent or damaged.
17. Do not use the On/WARM mode to reheat cold rice or other foods.
18. There are no user serviceable parts. If the power cord is damaged, it must be replaced by the manufacturer or similarly qualified person in order to avoid a hazard.
19. Do not operate the appliance if empty.
20. Do not use on an inclined plane or unstable surface.
21. Keep the appliance and the power cord away from the edges of benches and countertops and out of reach of children and persons with reduced physical, sensory and mental capacities.
22. When using this appliance, provide adequate air space above and on all sides for air circulation.
23. Do not operate this appliance while it is touching or near curtains, wall coverings, clothing, dish towels or other combustible materials.
24. Do not place on or near any heat sources.
25. Do not move the appliance whilst in use.
26. WARNING: After use, the appliance surfaces, contents and heating plate inside cooking base will remain hot for some time. Extreme caution must be used when moving an appliance containing hot foods and/or liquids.

- 27.** Do not use the appliance for other than its intended purpose.
- 28.** Misuse of this appliance may result in potential injury.
- 29.** This appliance is not intended to be operated by means of an external timer or separate remote control system.
- 30.** For added safety, electrical appliances should be connected to a power outlet that is protected by a residual current device (RCD), also often referred to as a 'Safety Switch'. Your switchboard may already incorporate an RCD. If unsure, call an electrician for verification and fitting if necessary.
- 31.** This appliance is intended to be used in household and similar applications such as:
 - Staff kitchen areas in shops, offices and other working environments;
 - Farm houses;
 - By clients in hotels, motels, and other residential type environments;
 - Bed & breakfast type environments.

SAVE THESE INSTRUCTIONS

Congratulations on the purchase of your Russell Hobbs appliance. Each unit is manufactured to ensure safety and reliability. **Before using the appliance for the first time, please read the instruction booklet carefully and keep it for future reference.** Pass it on if you pass on the appliance.

When using electrical appliances, basic safety precautions should always be followed.

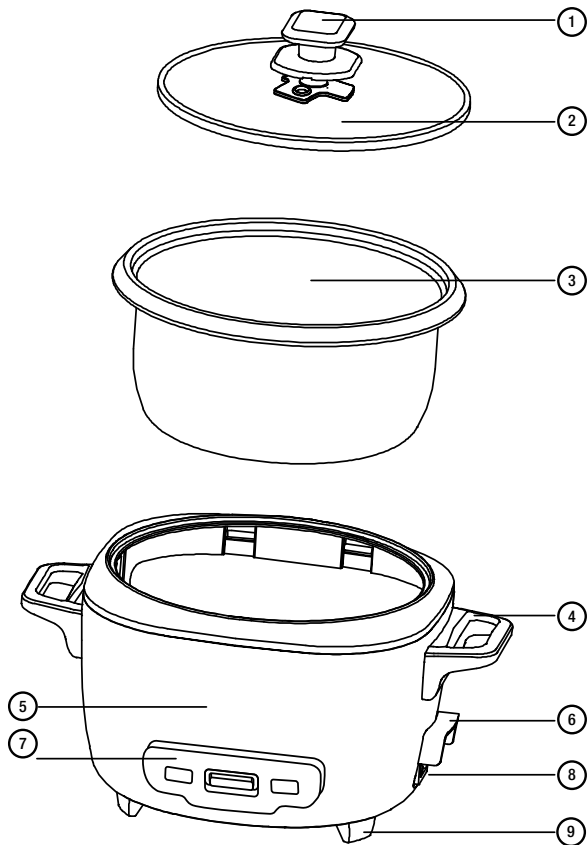

- 1. Lid handle
- 2. Glass lid
- 3. Cooking pot
- 4. Handle
- 5. Cooking base
- 6. Protective shroud
- 7. Control panel

- 8. Inlet
- 9. Feet

GETTING STARTED

- Remove all packing material, any stickers, and the plastic band around the power plug.
- Wash all removable parts as instructed in CARE AND CLEANING. Place the clean, dry cooking pot in the cooking base.
- Select a location where this unit is to be used. Place the unit on a stable, heat resistant surface, free from cloth, liquids and any other flammable materials. Ensure that the unit has enough space all the way around and above it to allow heat to flow without damage to cabinets or walls.
- Insert detachable power cord into the inlet on the side of the cooking base. Do not connect to and switch on the wall power outlet until ingredients have been added into cooking bowl and the bowl has been placed in cooking base.

IMPORTANT INFORMATION ABOUT YOUR RICE COOKER

- It is not necessary to preheat the rice cooker before use.
- The cooking bowl gets hot. When in use, always use oven mitts or potholders when touching any outer or inner surface of the appliance.
- During the first few minutes of use you may notice smoke and a slight odor. This is normal and will not impact the performance.
- Do not try to stop the rice cooker from switching to the warm mode.
- As rice cooks, steam will escape through vent in lid. Place glass lid on the rice cooker so the steam vent is facing away from cabinets and walls. Do not place hand over steam vent while rice is cooking; the hot steam may burn.
- Use the plastic serving spoon (or a wooden spoon) to stir and remove rice. Do not use metal utensils that can scratch the nonstick cooking bowl.
- Do not fill the cooking bowl higher than highest water marking measurement.

OPERATING YOUR RICE COOKER

COOKING RICE

1. Measure desired amount of rice with the provided measuring cup and add to the cooking bowl. The maximum amount of dry rice is 10 rice cup measures.

NOTE: A rice measuring cup has been supplied with this rice cooker and all measurements in these instructions relate to the supplied measuring cup.

2. Rinse the rice with water to remove any excess starch and then drain.
3. Add rice to cooking bowl and add required amount of water. Add butter, oil, or seasonings as desired. See the CHART FOR RICE COOKING IN THE HELPFUL HINTS section for additional details on water and rice measures for brown rice.
4. Place the cooking bowl into the cooking base and then place the lid on the bowl.
5. Plug in the appliance; the warm indicator light will automatically illuminate. The appliance will start heating on warm as soon as the cord is plugged into the outlet.
6. Push down the control switch. The cook indicator light will illuminate and the cooking will begin.
7. When the rice is ready, the control switch will flip up and switch to the warm setting.
8. For best results, allow the rice to rest on warm for 15 minutes with the lid in place. This will help further steam the rice. Always stir the rice with the serving spoon before serving.

NOTE: A thin crust may develop at the bottom of the bowl after standing.

9. Unplug the appliance when not in use and always allow the rice cooker to completely cool before cleaning.

COOKING SOUPS, STEWS, AND MORE

1. Add ingredients into the cooking bowl.
2. Place cooking bowl into the cooking base, then place the lid on the pot.
3. Plug in the appliance; the warm indicator light will automatically illuminate. The appliance will start heating on warm as soon as the cord is plugged into the outlet.
4. Push down the control switch. The cook indicator light will illuminate and the cooking will begin.
5. If desired, set kitchen timer for cooking time. Manually switch the appliance to warm when the food is ready by pushing up the control switch.

NOTE: The rice cooker will not switch to warm until all the liquids are boiled away. For best results, monitor cooking progress closely and do not leave the rice cooker unattended.

6. Unplug the appliance when not in use and always allow the rice cooker to completely cool before cleaning.

STEAMING IN THE STEAMING BASKET

1. Add the cooking bowl to the cooking base and then add ½ cups of water into the cooking bowl; adding seasoning if desired.
2. Place the foods to be steamed inside of the steaming basket and set the steaming basket inside of the cooking bowl. The water within the cooking bowl should not be touching the basket. Cover with lid and always keep lid on while steaming.
3. Plug in the appliance; the warm indicator light will automatically illuminate. The appliance will start heating on warm as soon as the cord is plugged into the outlet.
4. Push down the control switch. The cook indicator light will illuminate and the cooking will begin.
5. Steaming times vary between vegetables and other food types. Begin checking for doneness after the first 5 minutes.

NOTE: When steaming vegetables or other foods without rice in the cooking bowl, the unit will not automatically switch to warm.

6. Unplug the appliance when not in use and always allow the rice cooker to completely cool before cleaning.

COOKING RICE AND STEAMING VEGETABLES AT THE SAME TIME

1. Add the cooking bowl to the cooking base. Then add no more than two measures of dry rice and the amount of water listed in the CHART FOR RICE COOKING.
2. Frozen or fresh vegetables can be used. Place the foods to be steamed inside of the steaming basket and set the steaming basket inside of the cooking bowl. Cover with lid.
3. Push down the control switch. The cook indicator light will illuminate and the cooking will begin.
4. Steaming times vary. Begin checking for doneness after the first 5 minutes.
5. If the vegetables reach the desired doneness before the rice is done, carefully lift the steaming basket out of the cooking base and cover to keep warm. Immediately place the tempered glass lid back on the cooking pot while the rice continues to cook.
6. When the rice is ready, the control switch will flip up and switch to the warm setting.
7. For best results, allow the rice to rest on warm for 15 minutes with the lid in place. This will help further steam the rice. Always stir the rice with the serving spoon before serving.

NOTE: A thin crust may develop at the bottom of the bowl after standing.

8. Unplug the appliance when not in use and always allow the rice cooker to completely cool before cleaning.

CLEANING AND CARE

This product contains no user serviceable parts. Refer service to qualified service personnel.

CLEANING

IMPORTANT: Never immerse cooking base in water or other liquids.

1. Always unplug the rice cooker and allow to cool completely before cleaning.
2. Wash cooking bowl and glass lid in warm, soapy water. If food sticks to the cooking bowl, fill with warm, soapy water and allow it to soak before cleaning with plastic scouring pad

NOTE: Both the cooking bowl and glass lid are dishwasher safe.

3. Rinse and dry thoroughly.
4. Wipe interior and exterior of the cooking base with a soft, slightly damp cloth or sponge.

IMPORTANT: Never use abrasive cleansers or scouring pads to clean the cooking base, as they may damage the surfaces.

5. If water accidentally gets into the switch area or onto the heating plate, allow the rice cooker to dry completely before using.

STORING

Make sure that the appliance is thoroughly cool and dry. Never wrap the cord tightly around the appliance; keep it loosely coiled. Placing the lid on upsidedown for storage can help save space.

HELPFUL HINTS AND TIPS

RICE TIPS

- If rice or other foods start to boil over, remove the lid and stir for a couple minutes. Leaving the lid off for a short period of time will allow some of the liquids to boil off and for the mixture to slightly cool. Place the lid back on the rice cooker and repeat if needed.
- To reduce foaming, add a small amount of butter or oil to the water before cooking.
- Kosher salt has no impurities and dissolves faster than table salt. If using kosher salt, you may find you want to add a little more than if using table salt. About $\frac{3}{4}$ tsp. of kosher salt is recommended for each rice cup of uncooked rice.
- White rice can be stored in an airtight container in a cool dark place for up to one year.
- Brown rice can be stored in an airtight container in a cool dark place for up to six months. Refrigeration or freezing extends its shelf life.
- Try using broth, stock or reconstituted bouillon in place of water for additional flavor. If you do, no additional salt may be necessary.
- Do not keep small amounts of rice in the warm cycle for extended periods of time because it can dry out the rice.
- During cooking, a thin crust may develop on the rice at the bottom of the bowl. If you do not like rice with a crust, you can easily peel it off and discard it.
- Taste/firmness will vary depending on the quality/type of rice used and length of time it is cooked. For softer, fluffier rice, add a little more water. For firmer rice, use less water.
- For other types of grains not listed in the cooking chart, follow package directions.

ADDITIONAL USES FOR YOUR RICE COOKER

Packaged foods: condensed and ready to serve soups, pastas, and stews

- Do not fill bowl above the highest water marking cup level on the cooking bowl.
- For even heating, stir occasionally.
- Always use a kitchen timer. Do not rely on the control switch on the cooker since it is not intended to be an indicator of cooking time for soups and stews.
- Use only boneless meats and poultry that are cut into cubes no larger than 1½ inches. It is not necessary to brown the meats before cooking.
- When cooking rice or pasta in the soup, add additional liquid in the recipe.
- Since most frozen vegetables cook very quickly, it is best to add them at the end of the cooking time. Stir them into the soup or stew and allow the mixture to cook an additional 5 to 10 minutes.
- Choose recipes that will cook in 1 hour or less.

OATMEAL OR HOT CEREALS

- Steel Cut Oats work best.
- Do not fill bowl more than half way with liquids, as the oatmeal will expand during the cooking process.
- For even heating, stir occasionally.
- When the oatmeal is done, the rice cooker will switch to warm. Please note that this is for well-done oatmeal. If you prefer a different consistency, monitor the cooking process to manually switch to warm for desired results.
- Choose recipes that will cook in 1 hour or less.

CHART FOR RICE COOKING

If desired, add seasonings and oil or butter with rice before adding water. Allow rice to rest on warm at least 15 minutes before serving.

AMOUNT OF RICE	AMOUNT OF WATER	APPROX. COOKING TIME
FOR WHITE LONG GRAIN RICE		
2 rice measures	to bowl mark 2	12 to 17 minutes
4 rice measures	to bowl mark 4	15 to 20 minutes
6 rice measures	to bowl mark 6	19 to 24 minutes
8 rice measures	to bowl mark 8	21 to 26 minutes
10 rice measures	to bowl mark 10	24 to 29 minutes
FOR BROWN RICE		
2 rice measures	5 ½ cups	34 to 39 minutes
3 rice measures	8 cups	34 to 39 minutes
4 rice measures	10 cups	44 to 49 minutes
5 rice measures	11 cups	44 to 49 minutes
6 rice measures	12 cups	45 to 50 minutes
7 rice measures	13 cups	45 to 50 minutes
8 rice measures	14 cups	45 to 50 minutes

For other types of grains not listed in the cooking chart, follow package directions.

NOTE: When measuring uncooked rice use the rice measuring cup supplied with this rice cooker.

TROUBLESHOOTING

PROBLEM	POSSIBLE CAUSE	SOLUTION
Some kernels of rice do not seem fully cooked	<ul style="list-style-type: none"> • The rice was not allowed to finish cooking • There was not enough water in the cooking bowl. 	<ul style="list-style-type: none"> • Once the switch on the rice cooker automatically switches to keep warm, allow rice to rest for 15 minutes before serving. • Add a few more tablespoons of water and cook a little longer by pushing the control switch back to cook. Check the rice again when the appliance automatically switches back to warm and has rested for 15 minutes.
Rice cooking bowl is not as clean as I would like.	<ul style="list-style-type: none"> • Starch built up on sides and bottom of the bowl. 	<ul style="list-style-type: none"> • Fill the bowl with hot soapy water and let stand for several minutes; then use a nylon scrubber along sides and bottom. Rinse well.
Rice boils over.	<ul style="list-style-type: none"> • Too much rice is being cooked. • There is too much water for the amount of rice. 	<ul style="list-style-type: none"> • Make sure to cook no more than maximum amount suggested in the Instruction Manual. • Add a small amount (1 Tbs.) of butter or oil to water before cooking.
Rice is too dry.	<ul style="list-style-type: none"> • There is too much rice or not enough water. 	<ul style="list-style-type: none"> • Use the rice measuring cup that comes with the appliance. The rice measure provided holds $\frac{3}{4}$ cup (6 fluid oz.) of uncooked rice. Increase amount of water if rice is too dry to suit preference.
Rice is gummy.	<ul style="list-style-type: none"> • There is too much water or not enough rice. 	<ul style="list-style-type: none"> • Using the rice measuring cup that comes with the appliance. Reduce amount of water if rice is too gummy to suit preference.

Spectrum Brands Australia Pty Ltd

Locked Bag 3004 Braeside
Victoria 3195 Australia

Customer Service in Australia

TollFree: 1800 623 118
Email: info@spectrumbrands.com.au
Website: www.spectrumbrands.com.au

Spectrum Brands New Zealand Ltd

PO Box 9817 Newmarket
Auckland 1149 New Zealand

Customer Service in New Zealand

TollFree: 0800 736 776
Email: service@spectrumbrands.co.nz
Website: www.spectrumbrands.co.nz

Spectrum Brands Australia Pty Ltd and Spectrum Brands New Zealand Ltd Warranty Against Defects

In this warranty:

Australian Consumer Law means the Australian consumer law set out in Schedule 2 to the Competition and Consumer Act 2010;

CGA means the New Zealand Consumer Guarantees Act 1993;

Goods means the product or equipment which was accompanied by this warranty and purchased in Australia or New Zealand, as the case may be;

Manufacturer, We or us means:

1. for Goods purchased in Australia, Spectrum Brands Australia Pty Ltd ABN, 78 007 070 573;
or
2. for Goods purchased in New Zealand, Spectrum Brands New Zealand Ltd, as the case may be, contact details as set out at the end of this warranty;

Supplier means the authorised distributor or retailer of the Goods that sold you the Goods in Australia or in New Zealand; and

You means you, the original end-user purchaser of the Goods.

1. Our goods come with guarantees that cannot be excluded under the Australian Consumer Law, or the CGA. You are entitled to a replacement or refund for a major failure and compensation for any other reasonably foreseeable loss or damage. You are also entitled to have the goods repaired or replaced if the goods fail to be of acceptable quality and the failure does not amount to a major failure.
2. The benefits provided by this Warranty are in addition to all other rights and remedies in respect of the Goods which the consumer has under either the Australian Consumer Law or the CGA. The original purchaser of the Goods is provided with the following Warranty subject to the Warranty Conditions:
3. We warrant the Goods for all parts defective in workmanship or materials for a period of 2 years (**Warranty Period**) from the date of purchase.

If the Goods prove defective within the Warranty Period by reason of improper workmanship or material, we may, at our own discretion, repair or replace the Goods without charge.

Warranty Conditions

4. The Goods must be used in accordance with the manufacturer's instructions. This Warranty does not apply should the defect in or failure of the Goods be attributable to misuse, abuse, accident or non-observance of manufacturer's instructions on the part of the user. As far as the law permits, the manufacturer does not accept liability for any direct or consequential loss, damage or other expense caused by or arising out of any failure to use the Goods in accordance with the manufacturer's instructions.
5. Exhaustible components (such as batteries, filters and brushes) of the Goods are included under this Warranty only where there is a defect in workmanship or materials used.
6. The warranty granted under clause 3 is limited to repair or replacement only.
7. Any parts of the Goods replaced during repairs or any product replaced remain the property of the manufacturer. In the event of the Goods being replaced during the Warranty Period, the warranty on the replacement Goods will expire on the same date as for the Warranty Period on the original Goods which are replaced.
8. In order to claim under the warranty granted under clause 3 you must:
 - (a) Retain this warranty with your receipt/proof of purchase; and
 - (b) Return the Goods to us at the relevant address or to the Supplier by prepaid freight within the Warranty Period accompanied with (i) the legible and unmodified original proof of purchase, which clearly indicates the name and address of the Supplier, the date and place of purchase, the product name or other product serial number and (ii) this warranty.
9. This warranty is immediately void if:
 - (a) Any serial number or appliance plate is removed or defaced;
 - (b) The Goods have been serviced or otherwise repaired by a person not authorised to do so by us or where non approved replaced parts are used.
10. The Goods are designed for domestic use only. The Goods must be connected to the electrical voltage requirements as specified in the ratings label located on the Goods.
11. This warranty does not cover the cost of claiming under the warranty or transport of the Goods to and from the Supplier or us.
12. This warranty is only valid and enforceable in Australia against Spectrum Brands Australia Pty Ltd and in New Zealand against Spectrum Brands New Zealand Ltd.

Contact us or the Supplier for further details.

Register your product online

If you live in Australia please visit: www.spectrumbrands.com.au/warranty

If you live in New Zealand Please visit: www.spectrumbrands.co.nz/warranty

Registration of your warranty is not compulsory, it gives us a record of your purchase AND entitles you to receive these benefits: Product information; Hints and tips; Recipes and news; Information on special price offers and promotions.

Any questions? Please contact Customer Service for advice.



www.russellhobbs.com.au

www.russellhobbs.co.nz