



Russell Hobbs



BRITA GLASS KETTLE

2 YEAR WARRANTY

RHK550 SERIES

INSTRUCTIONS & WARRANTY

IMPORTANT SAFEGUARDS

When using electrical appliances, basic safety precautions should always be followed, including:

1. To protect against electrical hazards do not immerse the power cord, plug, power base, or kettle in water or any other liquid.
2. Do not use this appliance near bathtubs, showers, basins or other vessels containing water. Do not use outdoors.
3. **WARNING:** Avoid spillage on the power connectors.
4. Always use the appliances handles as some parts may be hot.
5. This appliance is not intended for use by persons (including children) with reduced physical, sensory or mental capabilities, or lack of experience and knowledge, unless they have been given supervision or instruction concerning use of the appliance by a person responsible for their safety.
6. Always turn off and unplug from the power outlet before cleaning the appliance.
7. Turn the power off at the wall power outlet when not in use.
8. To disconnect, turn off the wall power outlet, then grasp and pull the plug from the wall outlet. Never pull by the cord.
9. Do not operate this appliance with a damaged cord/plug or after the appliance has malfunctioned, or been dropped or damaged in any manner. Contact Customer Service for replacement, examination, repair or adjustment.
10. There are no user serviceable parts. If power cord is damaged, it must be replaced by the manufacturer or similarly qualified person in order to avoid a hazard.
11. **CAUTION:** Do not use on an inclined plane or unstable surface.
12. **CAUTION:** Do not move the kettle while it is switched on.
13. Ensure the lid is properly closed or the kettle may not switch off once boiled.
14. Do not open the lid while the water is heating or boiling.
15. Always take care when pouring. Pour slowly, do not over-tilt the kettle.
16. **WARNING:** The scalding hazard remains long after the water has boiled and the heating element surface is subject to residual heat after use.
17. Keep the kettle, power base, and the power cord away from the edge of tables or countertops and out of reach of children or persons with reduced physical, sensory and mental capacities.
18. Only use the kettle with the power base provided and vice versa.
19. Wind excess cable beneath the power base.
20. Do not place on or near any heat sources.
22. Do not use this appliance for other than its intended purpose of heating water.
22. **CAUTION:** Do not switch on the kettle unless there is at least one cup of water.
23. **WARNING:** Misuse may cause injury.
24. Do not fill past 'max', otherwise boiling water may be ejected from the spout.
25. Do not use without filter fitted.
26. Do not fill through the spout.
27. Do not leave the product unattended when in use or where it may be touched by children or persons with disabilities.
28. **CAUTION:** Do not use alkaline cleaning agents or harsh abrasives when cleaning this appliance. Follow the instructions in the 'Care and Maintenance' section when cleaning this appliance.
29. This appliance is not a toy. Children should be supervised to ensure they do not play with the appliance.
30. This appliance is not intended to be operated by means of an external timer or separate remote control system.
31. De-scale the kettle regularly to ensure proper operation.
32. For added safety, electrical appliances should be connected to a power outlet that is protected by a residual current device (RCD), also often referred to as a 'Safety Switch'. Your switchboard may already incorporate an RCD. If unsure, call an electrician for verification and fitting if necessary.
33. This appliance is intended to be used in household and similar applications such as:
 - staff kitchen areas in shops, offices and other working environments;
 - by clients in hotels, motels and other residential type environments;
 - bed and breakfast environments;
 - Farm houses.



SAVE THESE INSTRUCTIONS.

Congratulations on the purchase of your Russell Hobbs appliance. Each unit is manufactured to ensure safety and reliability. **Before using the appliance for the first time, please read the instruction booklet carefully and keep it for future reference.** Pass it on if you pass on the appliance.

When using electrical appliances, basic safety precautions should always be followed.

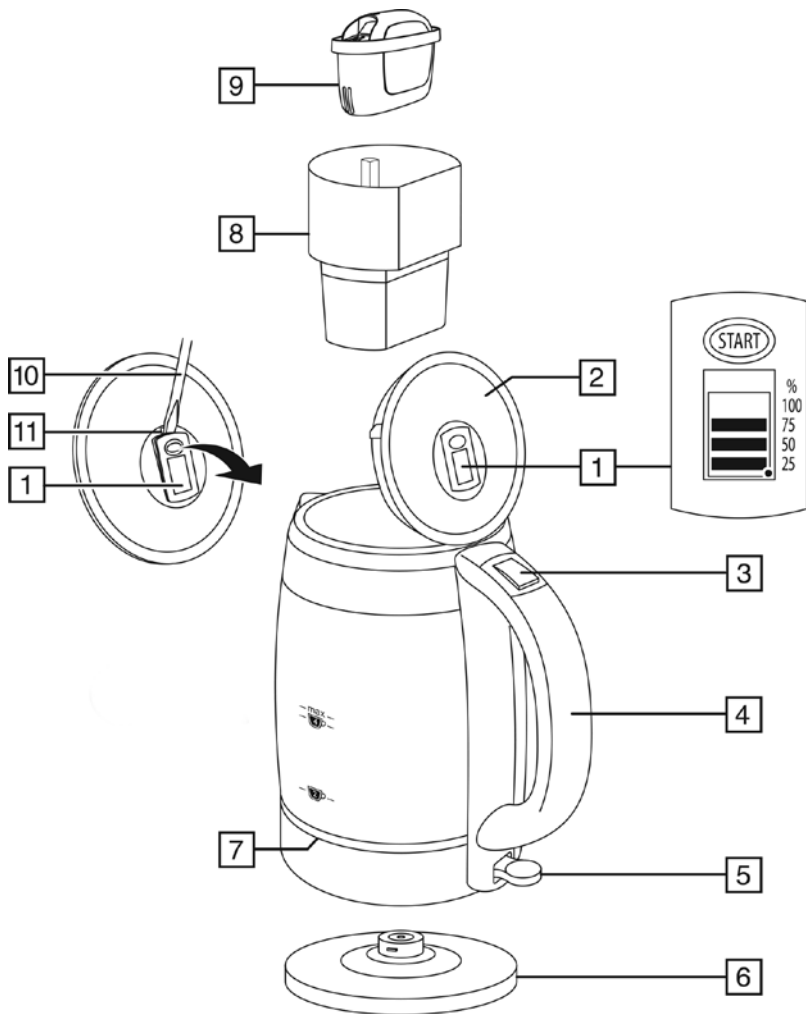

- | | |
|-------------------------|------------------------------------|
| 1. BRITA® Memo | 7. Light |
| 2. Lid | 8. Funnel |
| 3. Lid release | 9. BRITA® MAXTRA+ filter cartridge |
| 4. Handle | 10. Screwdriver |
| 5. Switch (O off, I on) | 11. Notch |
| 6. Stand | |

BRITA® MAXTRA+ FILTER CARTRIDGE

The filter cartridge contains ion exchange resin and activated carbon.

Reduces limescale and substances, e.g. chlorine, that affect taste and odour.

Reducing the impurities and permanently absorbing copper and lead, makes the water look and taste better, and the reduction in limescale helps your kettle too.

Remember – water goes off. Use filtered water within one day.

BEFORE USING FOR THE FIRST TIME

- Press the lid lock to open the lid.
- Remove the filter cartridge from inside the kettle
- Fill the kettle with water to the '**max**' level, boil, discard the water, and then rinse, to remove any dust, residues, etc., from the kettle. Repeat as required.

PREPARING THE FILTER CARTRIDGE

You can find more information about BRITA® filter cartridges and the BRITA® Memo in the BRITA® Information Guide supplied with the kettle.

1. Press the lid release button to open the lid.
2. To remove a filter cartridge, hold the funnel firmly with one hand, grip the top of the filter cartridge with the other hand and pull it up and out.
3. Remove all packaging from the new filter cartridge.
4. Don't worry if the inside of the packaging is damp – it's just condensation.
5. There might be black carbon particles in the packaging or on the filter cartridge. They are harmless.
6. To ensure efficient operation, all air must be removed from the filter cartridge.
7. Submerge the filter cartridge in a bowl of cold water and shake it gently till no more bubbles are released.
8. You may notice some black carbon particles floating in the water. Again, don't worry, they're harmless.
9. Before first use, you must flush the filter cartridge.
10. Push the filter cartridge into the funnel till it won't go any further.
11. Fill the funnel quickly. It will take up to 2.5 minutes for the water to filter into jug.
12. Fill it again when it empties.
13. This should fill the kettle to about the **max** mark.
14. Discard the water, and repeat the operation.
15. When you've discarded two lots of water, the filter cartridge is ready for use.

RESET THE BRITA® MEMO

This shows what proportion of the filter cartridge's 4 week life is left.

1. Press and hold the START button till all 4 bars appear and flash twice, then let go.
2. Every week, one bar will disappear.
3. When all 4 bars disappear, a flashing arrow will appear at the top of the display. This means it's time to replace the filter cartridge.
4. When the display gets down to one bar, it's a good idea to check that you've got another filter cartridge available. If you haven't, it's time to buy some.
5. The flashing dot at the bottom right of the display shows that the Memo is working.

HOLIDAYS

If you haven't used the kettle for a few days:

- Empty the kettle and rinse it out
- Flush the filter cartridge (see points 10-15 in the 'preparing the filter cartridge' section)

POSITIONING

- Place the base on a stable, level surface.
- Route the cable so it does not overhang, and cannot be caught or tripped over.
- Wind excess cable beneath the base.
- Position your kettle to ensure the spout directs steam away from curtains, drapes and overhead cupboards.

FILLING

Caution: If the kettle has just boiled it will be full of steam. Keep hands clear as steam will escape from the kettle when opening the lid.

1. Press the lid release button to open the lid.
2. Fill with at least 2 cups of water, but not above **max**.
3. Fill the funnel quickly. It will take up to 2.5 minutes for the water to filter into jug.
4. Fill it again when it empties.
5. This should fill the kettle to about the **max** mark. The water capacity is 1.7L without the filter and 1L with filter inside the jug.
6. If the water level is above the **max** mark, pour some water out of the kettle.
7. Close the lid, and press down to lock it.
8. Check the lid is fully closed or the kettle may not switch off when it boils.

SWITCHING ON

Caution: Keep clear, as steam will escape from the spout when boiling.

- Plug the power cord into the wall power outlet and switch it on.
- Place the kettle on the power base – take care not to spill any water.
- Move the switch to I. The light will come on, and the kettle will heat up.

SWITCHING OFF

- When the water boils the kettle will switch off and the light will go out.
- To switch off manually, move the switch to O.

GENERAL

- Remove the kettle from the power base before pouring.
- To avoid the risk of splashing, pour slowly and do not over-tilt the kettle.
- Do not tilt the kettle backwards as water might get into the control area.
- If this happens, empty any remaining water and allow the kettle to dry before further use – sit it somewhere warm for 12 hours.
- You may see some discolouration on the floor of the kettle. Again, don't worry – it's due to the bonding of the element to the kettle floor.

USING WITH INSUFFICIENT WATER

- Using the kettle with insufficient water will shorten the life of the element.
- If the kettle is accidentally switched on when it does not contain sufficient water, a boil-dry cut-out will switch the kettle off.
- To prevent the kettle cycling on and off, remove it from the power base and the boil switch will pop up.
- Sit the kettle on a stable heat resistant surface until it has fully cooled down.
- Do not fill the kettle with water until it is cold, or it may spit.

CARE AND MAINTENANCE

- Switch the power off and remove the plug from the wall power outlet.
- Allow the kettle to cool down fully.
- Wipe over the outside of the kettle and power base with a damp cloth. A mild dishwashing detergent may be used if required.
- Keep all connectors and sockets dry.
- Do not immerse the kettle or power base in liquid.
- Do not use alkaline cleaning agents or harsh abrasives when cleaning this appliance.
- Clean the inside of the kettle using the instructions in the “DE-SCALE REGULARLY” section. The filter and the funnel should be removed prior to de-scaling.

DE-SCALE REGULARLY – EVEN IN SOFT WATER AREAS

Water contains minerals that will form deposits on the inside of your kettle, commonly referred to as scaling. Scaling discolours the internal surfaces and can affect the heating and noise performance.

To maintain the performance of your kettle, it should be de-scaled every three months or so. De-scale more frequently if you live in a hard water area.

- Add a commercially available de-scaler to the empty kettle, in accordance with the instructions on the de-scaler packaging (Available from your supermarket).
- Fill the kettle with fresh cold water to the **max** level mark on the water gauge.
- Switch the ON/OFF switch to ON and allow the kettle to boil.
- Once the water has boiled allow the kettle to cool.
- Once the kettle has cooled, discard the water into the sink.

RINSE AFTER DE-SCALING

- Fill the kettle with fresh cold water to the **max** level mark on the water gauge.
- Switch the ON/OFF switch to ON and allow the kettle to boil.
- Discard the water into the sink.
- Rinse 1 or 2 times further with fresh water as required.

NOTE: *Products returned under warranty with faults due to scale may be subject to a repair charge.*

THE FUNNEL

1. Open the lid.
2. Put your thumbs inside the funnel.
3. Gently press one thumb against either side of the funnel and lift it out of the kettle.

DISPOSAL

Sadly, nothing lasts forever, and the day will come when your appliance comes to the end of its natural life.

The appliance contains a battery, which must be removed from the appliance.

Put the end of a screwdriver in the notch above the Memo, and prise it out of the lid.

Spectrum Brands Australia Pty Ltd

Locked Bag 3004 Braeside
Victoria 3195 Australia

Customer Service in Australia

TollFree: 1800 623 118
Email: info@spectrumbrands.com.au
Website: www.spectrumbrands.com.au

Spectrum Brands New Zealand Ltd

PO Box 9817 Newmarket
Auckland 1149 New Zealand

Customer Service in New Zealand

TollFree: 0800 736 776
Email: service@spectrumbrands.co.nz
Website: www.spectrumbrands.co.nz

Spectrum Brands Australia Pty Ltd and Spectrum Brands New Zealand Ltd Warranty Against Defects

In this warranty:

Australian Consumer Law means the Australian consumer law set out in Schedule 2 to the Competition and Consumer Act 2010;

CGA means the New Zealand Consumer Guarantees Act 1993;

Goods means the product or equipment which was accompanied by this warranty and purchased in Australia or New Zealand, as the case may be;

Manufacturer, We or us means:

1. for Goods purchased in Australia, Spectrum Brands Australia Pty Ltd ABN, 78 007 070 573;
or
2. for Goods purchased in New Zealand, Spectrum Brands New Zealand Ltd, as the case may be, contact details as set out at the end of this warranty;

Supplier means the authorised distributor or retailer of the Goods that sold you the Goods in Australia or in New Zealand; and

You means you, the original end-user purchaser of the Goods.

1. Our goods come with guarantees that cannot be excluded under the Australian Consumer Law, or the CGA. You are entitled to a replacement or refund for a major failure and compensation for any other reasonably foreseeable loss or damage. You are also entitled to have the goods repaired or replaced if the goods fail to be of acceptable quality and the failure does not amount to a major failure.
2. The benefits provided by this Warranty are in addition to all other rights and remedies in respect of the Goods which the consumer has under either the Australian Consumer Law or the CGA. The original purchaser of the Goods is provided with the following Warranty subject to the Warranty Conditions:
3. We warrant the Goods for all parts defective in workmanship or materials from the date of purchase, for the period of 2 years from the date of purchase (**Warranty Period**).

If the Goods prove defective within the Warranty Period by reason of improper workmanship or material, we may, at our own discretion, repair or replace the Goods without charge.

Warranty Conditions

4. The Goods must be used in accordance with the manufacturer's instructions. This Warranty does not apply should the defect in or failure of the Goods be attributable to misuse, abuse, accident or non-observance of manufacturer's instructions on the part of the user. As far as the law permits, the manufacturer does not accept liability for any direct or consequential loss, damage or other expense caused by or arising out of any failure to use the Goods in accordance with the manufacturer's instructions.
5. Exhaustible components (such as batteries, ironing board cover, filters and brushes) of the Goods are included under this Warranty only where there is a defect in workmanship or materials used.
6. The warranty granted under clause 3 is limited to repair or replacement only.
7. Any parts of the Goods replaced during repairs or any product replaced remain the property of the manufacturer. In the event of the Goods being replaced during the Warranty Period, the warranty on the replacement Goods will expire on the same date as for the Warranty Period on the original Goods which are replaced.
8. In order to claim under the warranty granted under clause 3 you must:
 - (a) Retain this warranty with your receipt/proof of purchase; and
 - (b) Return the Goods to us at the relevant address or to the Supplier by prepaid freight within the Warranty Period accompanied with (i) the legible and unmodified original proof of purchase, which clearly indicates the name and address of the Supplier, the date and place of purchase, the product name or other product serial number and (ii) this warranty.
9. This warranty is immediately void if:
 - (a) Any serial number or appliance plate is removed or defaced;
 - (b) The Goods have been serviced or otherwise repaired by a person not authorised to do so by us or where non approved replaced parts are used.
10. The Goods are designed for domestic use only. The Goods must be connected to the electrical voltage requirements as specified in the ratings label located on the Goods.
11. This warranty does not cover the cost of claiming under the warranty or transport of the Goods to and from the Supplier or us.
12. This warranty is only valid and enforceable in Australia against Spectrum Brands Australia Pty Ltd and in New Zealand against Spectrum Brands New Zealand Ltd.

Contact us or the Supplier for further details.

Register your product online

If you live in Australia please visit: www.spectrumbrands.com.au/warranty

If you live in New Zealand Please visit: www.spectrumbrands.co.nz/warranty

Registration of your warranty is not compulsory, it gives us a record of your purchase AND entitles you to receive these benefits: Product information; Hints and tips; Recipes and news; Information on special price offers and promotions.

Any questions? Please contact Customer Service for advice.



www.russellhobbs.com.au

www.russellhobbs.co.nz