



# Russell Hobbs



## FOOD PROCESSOR

2 YEAR WARRANTY

RHFPT1

RHFPT1\_IB&RB\_FA\_171016 Part No. T22-5003437

INSTRUCTIONS & WARRANTY

## **IMPORTANT SAFEGUARDS**

When using this appliance, basic safety precautions should always be followed, including but not limited to the following:

1. To protect against electric shock do not immerse cord, plug or body of unit in water or liquid.
2. Do not use outdoors or in damp or moist areas.
3. This appliance is not intended for use by persons (including children) with reduced physical, sensory or mental capabilities, or lack of experience and knowledge, unless they have been given supervision or instruction concerning use of the appliance by a person responsible for their safety.
4. This appliance is not a toy. Young children should be supervised to ensure they do NOT play with the appliance.
5. Always turn off and unplug from the power outlet when not in use, before putting on or taking off parts, and before cleaning the appliance.
6. Do not operate any appliance with a damaged cord or plug or after the appliance has malfunctioned, or has been dropped or damaged in any manner. Contact customer service for replacement, examination, repair or adjustment.
7. There are no user serviceable parts. If the power cord is damaged, it must be replaced by the manufacturer or a suitably qualified person in order to avoid a hazard.
8. The use of accessory attachments not recommended by the appliance manufacturer may cause injuries.
9. Do not use on an inclined plane or unstable surface.
10. Keep the processor and power cord away from the edge of benches and counter tops.
11. Do not place on or near any heat surfaces.
12. To disconnect, press OFF. Turn off the wall power outlet, then grasp the plug and remove from wall outlet. Never pull by the cord.
13. Do not use appliance for other than its intended purpose.
14. The motor will only operate once the processing bowl and lid have been securely fitted onto the motor unit.
15. Keep hands and utensils away from moving blades or discs while processing foods to prevent the possibility of severe personal injury or damage to the food processor. A scraper may be used, but it must be used only when the food processor is not running.
16. Misuse of the appliance may cause injury.
17. Cutting blades are very sharp. Care must be taken when handling the sharp cutting blades, when emptying the bowl and during cleaning.
18. To reduce the risk of injury, never place cutting blade or disc on base without first fitting the bowl securely in place.
19. Be certain cover is securely locked in place before operating appliance.
20. Never feed food into chute by hand. Always use the food pusher.
21. Do not attempt to defeat the cover interlock mechanism.
22. Press OFF to cancel any function.
23. Do not operate from a timer or other remote control system
24. For added safety, electrical appliances should be connected to a power outlet that is protected by a residual current device (RCD), also often referred to as a 'Safety Switch'. Your switchboard may already incorporate an RCD. If unsure, call an electrician for verification and fitting if necessary.

**SAVE THESE INSTRUCTIONS  
THIS APPLIANCE IS FOR HOUSEHOLD USE ONLY**

## **Spectrum Brands Australia Pty Ltd**

Locked Bag 3004 Braeside  
Victoria 3195 Australia

### **Customer Service in Australia**

TollFree: 1800 623 118  
Email: info@spectrumbrands.com.au  
Website: www.spectrumbrands.com.au

## **Spectrum Brands New Zealand Ltd**

PO Box 9817 Newmarket  
Auckland 1149 New Zealand

### **Customer Service in New Zealand**

TollFree: 0800 736 776  
Email: service@spectrumbrands.co.nz  
Website: www.spectrumbrands.co.nz

## **Spectrum Brands Australia Pty Ltd and Spectrum Brands New Zealand Ltd Warranty Against Defects**



In this warranty:

**Australian Consumer Law** means the Australian consumer law set out in Schedule 2 to the Competition and Consumer Act 2010;

**CGA** means the New Zealand Consumer Guarantees Act 1993;

**Goods** means the product or equipment which was accompanied by this warranty and purchased in Australia or New Zealand, as the case may be;

**Manufacturer, We** or **us** means:

1. for Goods purchased in Australia, Spectrum Brands Australia Pty Ltd ABN, 78 007 070 573;  
or
2. for Goods purchased in New Zealand, Spectrum Brands New Zealand Ltd, as the case may be, contact details as set out at the end of this warranty;

**Supplier** means the authorised distributor or retailer of the Goods that sold you the Goods in Australia or in New Zealand; and

**You** means you, the original end-user purchaser of the Goods.

1. Our goods come with guarantees that cannot be excluded under the Australian Consumer Law, or the CGA. You are entitled to a replacement or refund for a major failure and compensation for any other reasonably foreseeable loss or damage. You are also entitled to have the goods repaired or replaced if the goods fail to be of acceptable quality and the failure does not amount to a major failure.
2. The benefits provided by this Warranty are in addition to all other rights and remedies in respect of the Goods which the consumer has under either the Australian Consumer Law or the CGA. The original purchaser of the Goods is provided with the following Warranty subject to the Warranty Conditions:
3. We warrant the Goods for all parts defective in workmanship or materials from the date of purchase (**Warranty Period**), for the period of 2 years from the date of purchase (**Warranty Period**).

If the Goods prove defective within the Warranty Period by reason of improper workmanship or material, we may, at our own discretion, repair or replace the Goods without charge.

## **Warranty Conditions**

4. The Goods must be used in accordance with the manufacturer's instructions. This Warranty does not apply should the defect in or failure of the Goods be attributable to misuse, abuse, accident or non-observance of manufacturer's instructions on the part of the user. As far as the law permits, the manufacturer does not accept liability for any direct or consequential loss, damage or other expense caused by or arising out of any failure to use the Goods in accordance with the manufacturer's instructions.
5. Exhaustible components (such as batteries, filters and brushes) of the Goods are included under this Warranty only where there is a defect in workmanship or materials used.
6. The warranty granted under clause 3 is limited to repair or replacement only.
7. Any parts of the Goods replaced during repairs or any product replaced remain the property of the manufacturer. In the event of the Goods being replaced during the Warranty Period, the warranty on the replacement Goods will expire on the same date as for the Warranty Period on the original Goods which are replaced.
8. In order to claim under the warranty granted under clause 3 you must:
  - (a) Retain this warranty with your receipt/proof of purchase; and
  - (b) Return the Goods to us at the relevant address or to the Supplier by prepaid freight within the Warranty Period accompanied with (i) the legible and unmodified original proof of purchase, which clearly indicates the name and address of the Supplier, the date and place of purchase, the product name or other product serial number and (ii) this warranty.
9. This warranty is immediately void if:
  - (a) Any serial number or appliance plate is removed or defaced;
  - (b) The Goods have been serviced or otherwise repaired by a person not authorised to do so by us or where non approved replaced parts are used.
10. The Goods are designed for domestic use only. The Goods must be connected to the electrical voltage requirements as specified in the ratings label located on the Goods.
11. This warranty does not cover the cost of claiming under the warranty or transport of the Goods to and from the Supplier or us.
12. This warranty is only valid and enforceable in Australia against Spectrum Brands Australia Pty Ltd and in New Zealand against Spectrum Brands New Zealand Ltd.

Contact us or the Supplier for further details.

### **Register your product online**

If you live in Australia please visit: [www.spectrumbrands.com.au/warranty](http://www.spectrumbrands.com.au/warranty)

If you live in New Zealand Please visit: [www.spectrumbrands.co.nz/warranty](http://www.spectrumbrands.co.nz/warranty)

Registration of your warranty is not compulsory, it gives us a record of your purchase AND entitles you to receive these benefits: Product information; Hints and tips; Recipes and news; Information on special price offers and promotions.

**Any questions?** Please contact Customer Service for advice.

Congratulations on the purchase of your new Russell Hobbs appliance. Each unit is manufactured to ensure safety and reliability. **Before using the appliance for the first time, please read this instruction booklet carefully and keep it for future reference.** Pass it on if you pass on the appliance.

When using electrical appliances, basic safety precautions should always be followed.

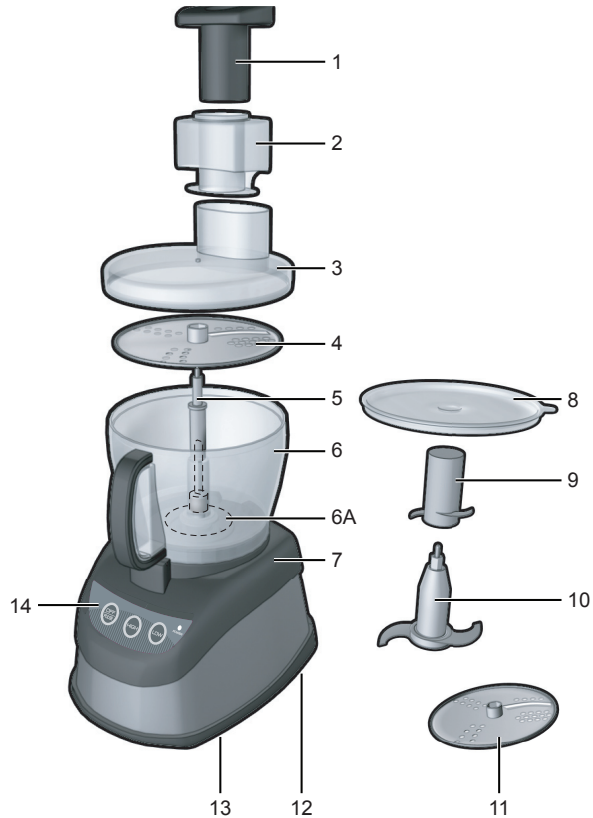

- |  |  |
|--|--|
| 1. Food pusher                                   | 8. Storage lid                                   |
| 2. Wide-mouth feed chute                         | 9. Dough blade                                   |
| 3. 10 cup processing workbowl cover              | 10. Large stainless steel chopping blade (White) |
| 4. Coarse slice/shred disc                       | 11. Fine slice/shred disc                        |
| 5. Disc stem                                     | 12. Cord wrap (under base)                       |
| 6. 10 cup processing workbowl<br>6A. Centre Post | 13. Non-slip suction feet                        |
| 7. Base  | 14. Controls                                     |

**Important: Please read the below two points before using you Food Processor.**

## **TAMPER-RESISTANT SCREW**

Warning: This appliance is equipped with a tamper-resistant screw to prevent removal of the outer cover. To reduce the risk of fire or electric shock, do not attempt to remove the outer cover. There are no user-serviceable parts inside. Repair should be done only by qualified service personnel.

## **ELECTRICAL CORD**

The cord of this appliance was selected to reduce the possibility of tangling in or tripping over a longer cord. If more length is needed, use an extension cord rated no less than 10 amperes. When using an extension cord, do not let it drape over the working area or dangle where someone could accidentally trip over it. Handle cord carefully for longer life; avoid jerking or straining it at outlet and appliance connections. The maximum rating is based on the chopping blade; other attachments may draw significantly less power.

## **BEFORE FIRST USE**

**CAUTION: Handle chopping blades and slice/grate disc carefully.**



- Remove all packaging material and any stickers from the product. Wash all removable parts as instructed in “CARE AND CLEANING” section of this manual.
- Select a level, dry countertop where the appliance is to be used, allowing air space on all sides to provide proper ventilation for the motor (50mm gap min).

## **ASSEMBLY OF THE PROCESSOR BOWL**

### **HOW TO INSERT AND REMOVE THE CENTRE POST**

- The centre post of the bowl is removable.
- Turn the bowl upside down.
- Grasp the outer tabs and turn the centre post clockwise until the locking tabs are free. Lift the post out (A).
- To return to its original position, place centre post into opening in bottom of workbowl and turn counter-clockwise until tabs snap into place.

### **HOW TO LOCK THE WORKBOWL IN POSITION:**

- Place the workbowl on the base with handle turned to the right of the locking mechanism (B) over the unlock symbol .
- Hold handle and rotate workbowl clockwise toward the lock symbol  until it clicks firmly into place (C). Be sure to lock the workbowl in place before attaching the blades and cover.

### **HOW TO LOCK THE COVER**

- Place cover over workbowl with the small latch to the right of the workbowl's handle (D).
- Hold workbowl cover and rotate clockwise until cover locks into place.

**Important: For your protection this appliance has an interlock system. The processor will not operate unless the workbowl, cover and wide-mouth feed chute are properly locked in place.**

- Place the wide-mouth feed chute on top of the cover with the small tab to the right of the workbowl's handle. Turn clockwise until it clicks into position in the handle.
- Insert the food pusher into the central tube of the wide mouth feed chute. Turn clockwise to lock in place. The pusher is used to guide foods through the feed chute and can be removed when adding liquid or additional foods while the processor is running.
- To remove, turn anticlockwise.

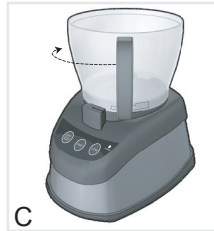

## CONTROLS

- The controls are located on the front of the base (E).
- Press PULSE, HIGH or LOW to select a function (see directions below).

## OFF/PULSE

- Processor should be stored in OFF position and unplugged when not in use.
- Use PULSE for short processing tasks. This lets you control the size and uniformity of foods being chopped.
- The OFF/PULSE button must be pressed and held for the appliance to operate in PULSE mode. When released, the appliance will stop.
- The motor of the processor will run as long as the OFF/PULSE button is held down.
- Press the button and then release to allow the blades to stop running and the food to fall to the bottom of the workbowl.
- Pulsing gives better control when chopping, mincing, mixing and blending foods. You can control the size of the foods, from coarse to fine.

## HIGH AND LOW

- When either speed is selected, the processor will run continuously until the OFF/PULSE button is pressed.



## HOW TO CHOP IN THE WORKBOWL

The chopping blade is used to coarsely or finely chop, mince, mix and puree foods to a smooth consistency.

- Lock workbowl into position (see Illustrations B and C).
- Hold chopping blade by centre shaft and insert onto centre post (F).

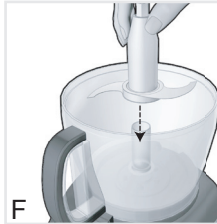

**CAUTION:** The blade attachments are very sharp. Use caution when handling and storing.

- Place food in workbowl.
- Place cover on workbowl and lock into place by rotating clockwise (see Illustration D).
- Place the wide-mouth feed chute and food pusher in place, turn to lock.

**CAUTION:** Never use your fingers to direct food through the chute.

- Select your desired speed (PULSE, LOW or HIGH).

*NOTE: Process foods for no more than a few seconds at a time. Pulsing produces excellent results and offers greater control.*

- Food can be added while processor is running; remove food pusher and insert food through the feed chute. Replace food pusher in chute.

**CAUTION:** Be sure chopping blade has completely stopped spinning before removing cover from processor.

- Press the OFF/PULSE button and allow blades to stop revolving before removing cover. Twist cover toward  to remove.
- Unlock workbowl by turning it anti-clockwise and lift off base.

*NOTE: Remove bowl from appliance before removing blade to prevent food from leaking through the centre opening of the bowl.*

- Carefully remove chopping blade.
- Unplug appliance when not in use.

## HELPFUL TIPS FOR CHOPPING AND BLENDING

- The processor works very quickly. Watch carefully to avoid over-processing foods.
- The PULSE button offers the best control and results. Process using PULSE in 5 second intervals.
- For best results, process foods that are about the same size.
- The workbowl has a capacity of 2L.
- Do not overload the bowl.
- Do not process more than 3 cups of liquid in the workbowl at one time.
- Insert a funnel into the feed chute when adding ingredients such as, oil, flour and sugar.
- Do not process boiling liquids.
- To process meat, use no more than 2 cups of 20mm cubes in the workbowl.



## HOW TO USE THE DOUGH BLADE (SAME ASSEMBLY METHOD AS THE CHOPPING BLADE)

*This blade makes preparing dough efficient and time-saving.*

*NOTE: This blade does not extend to the outside rim of the workbowl, so it cannot incorporate flour when very small amounts of flour are being processed.*

- Push dough blade down as far as it will go into workbowl.
- Insert all the dry ingredients into the workbowl.
- Place cover on workbowl. Add wide-mouth feed chute and food pusher. Process to blend.
- Add liquids through the small feed chute with machine running.

## HELPFUL TIPS WHEN USING THE DOUGH BLADE

- For best results do not prepare recipes using more than 3½ cups flour.
- Begin with 1 cup less than the maximum amount of flour and add additional flour once mixture is well blended.
- Pour liquid through food chute gradually.
- Knead dough no longer than 1 minute.

## HOW TO SLICE OR GRATE

- Lock workbowl into position (see Illustrations B and C).
- Place disc stem onto centre post in workbowl.
- Carefully place slice/grate disc on stem with appropriate side up (depending on work to be done).

**CAUTION: The blade attachments are very sharp. Use caution when handling and storing.**

- Place cover on workbowl and lock into place by rotating cover clockwise (see Illustration D).
- For large size food insert before attaching the chute, then attach chute and use the pusher Fig G(a). For smaller size food, attach cover and feed through using pusher.

*NOTE that the pusher clips onto the moving chute tube. Fig G.*

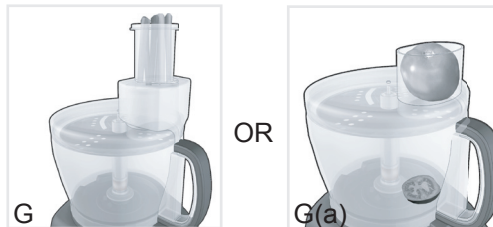

- Select PULSE, LOW or HIGH; press firmly on food pusher to guide food through processor, but do not force it.

*NOTE: Heavy pressure on the pusher does not speed the work; use the pusher only as a guide. Let the processor do the work.*

- When finished, press OFF/PULSE and wait for disc to stop rotating before removing cover. Twist cover toward to remove.
- Carefully remove slice/grate disc. Unlock workbowl by turning it counter-clockwise and lifting it off the base.
- Unplug appliance when not in use.

## **HELPFUL TIPS WHEN SLICING AND GRATING**

- Before slicing round fruits and vegetables in the processor, cut a thin slice from the bottom so food will be more stable. Place food cut side down in feed chute.
- Always remove seeds and pits before processing.
- Remove the core from hard vegetables, such as cabbage.
- When slicing thinner vegetables, cut them just short of the length of the feed chute and stand them vertically in feed chute so they are solidly packed and cannot turn or tilt.
- Grate hard cheeses at room temperature.
- Soft and semi-hard cheeses should be well chilled before grating.
- After food has been processed, remove the cover and invert on countertop. Remove the slice/grate disc before removing the workbowl from the processor. Place the disc on top of the inverted workbowl cover.

## **GENERAL TIPS FOR USING THE FOOD PROCESSOR**

- Organize processing tasks to avoid multiple cleanups of the bowl; process dry before wet.
- The processor will be more efficient if filled no more than 2/3 full.
- To take advantage of the speed of the processor, drop foods through the food chute with the processor running.
- Apply light pressure on the pusher for soft foods (berries and tomatoes) and slightly more pressure for hard foods (onions and potatoes).
- Do not process foods that are so frozen or so hard that the tip of a knife cannot be inserted into the food.
- When chopping dried fruits add a little flour to keep the pieces from sticking together.
- Chill soft cheeses before slicing and grating to prevent the cheese from rolling into a ball on the disc.
- When using the slicing / grating disc do not let the food accumulate too high; stop and empty the workbowl.
- Although plastic parts of the processor are dishwasher safe, wash them by hand to retain their clear appearance.
- To easily clean the workbowl, once empty add a drop of detergent and a little hot water and pulse several times. Rinse before reusing.
- Do not use the processor to:
  - Grind bones, grains or hard spices
  - Liquefy fruits and vegetables
  - Slice warm meat and hard cooked eggs; chill them first.

## **SPEED SETTING USE**

### **LOW**

- Reconstituting frozen juices and drink mixes
- Preparing salad dressings
- Pureeing hot soups
- Blending pancake and waffle batter or mixes
- Beating eggs for omelettes and custards
- Making cookie crumbs and bread crumbs
- Preparing sauces and salsa

### **HIGH**

- Coarse to fine chopping of nuts, vegetables and fruits
- Grinding hard cheeses, spices and coffee beans
- Baby foods – fruits and vegetables

### **PULSE**

- Chopping vegetables
- Thick beverages

## **CARE AND CLEANING**

*NOTE: Before cleaning, be sure unit is turned off and cord is unplugged.*

- Completely disassemble processor parts before washing.
- Whenever possible, rinse parts immediately after processing for easy cleanup.
- Wipe base and feet with a damp cloth and dry thoroughly. Stubborn spots can be removed by rubbing with a damp cloth and a mild, nonabrasive cleaner. Do not immerse base in liquid.
- All removable parts can be washed by hand or in a dishwasher. Hand washing of plastic parts will help to maintain the processor's appearance.
- If washing by hand, fill workbowl with hot soapy water and rapidly raise and lower the cutting blade and discs up and down on the centre shaft.
- If your sink has a sprayer nozzle, you will find it helpful in rinsing the blades.
- If washing in a dishwasher, place removable parts on top rack only – not in or near utensil basket.
- Some staining of parts may occur. Make a paste of 2 tablespoons baking soda / 1 tablespoon water. Apply to stains and let stand overnight. Rinse and dry.
- Do not use rough scouring pads or cleansers on any plastic or metal parts.
- Do not allow blades or discs to soak in water for long periods of time.
- Remove the workbowl cover and blade. Invert an empty 35mm film canister over the hole in the workbowl. Fill with hot, soapy water and allow to soak.
- Remember to clean the internal shaft of the chopping blade; use a baby bottle brush to remove any clogged food particles.
- If you are having trouble closing the cover over the workbowl, apply a small amount of vegetable oil to the rim of the cover and workbowl. This should make the pieces work smoother when attaching the cover to the bowl.

***CAUTION: Do not attempt to sharpen the cutting edges of the blades or disc. They are permanently sharpened at the factory and will be ruined by attempted sharpening.***

## TROUBLESHOOTING

PROBLEM	POSSIBLE CAUSE	SOLUTION
<ul style="list-style-type: none"> <li>Food is unevenly chopped.</li> </ul>	<ul style="list-style-type: none"> <li>Workbowl is overfilled.</li> <li>You may be running the bowl continuously instead of using PULSE.</li> <li>Food may be cut in random sizes.</li> </ul>	<ul style="list-style-type: none"> <li>Smaller amounts will process more evenly.</li> <li>Use the PULSE button in 5 second increments or less. Allow the blades to stop completely before pressing the PULSE button again.</li> <li>Cut food in same size pieces before placing in processor.</li> </ul>
<ul style="list-style-type: none"> <li>Liquid leaks from the bottom of the workbowl.</li> </ul>	<ul style="list-style-type: none"> <li>Too much liquid in the workbowl.</li> </ul>	<ul style="list-style-type: none"> <li>Process smaller amounts.</li> <li>When processing liquids, do not add more than 3 cups to workbowl.</li> <li>Do not remove the blade before removing workbowl from processor when processing liquids.</li> </ul>
<ul style="list-style-type: none"> <li>Sliced foods are uneven and slanted.</li> </ul>	<ul style="list-style-type: none"> <li>The feed chute has not been well packed or uneven pressure has been applied to the food pusher during processing.</li> </ul>	<ul style="list-style-type: none"> <li>Cut pieces in even lengths, just a little shorter than the length of the feed chute.</li> <li>Pack the chute carefully and maintain even pressure on the food pusher as the food is being processed.</li> </ul>
<ul style="list-style-type: none"> <li>Foods being sliced or grated fill up on one side of the bowl.</li> </ul>	<ul style="list-style-type: none"> <li>This is normal.</li> </ul>	<ul style="list-style-type: none"> <li>Stop processing occasionally and either, even out the food in the workbowl or move it to another bowl.</li> <li>When food accumulates close to the disc, empty the workbowl before continuing.</li> </ul>
<ul style="list-style-type: none"> <li>Some pieces of food remain on top of the slice/grate disc.</li> </ul>	<ul style="list-style-type: none"> <li>This is normal.</li> </ul>	<ul style="list-style-type: none"> <li>Slice or grate those pieces by hand or save for another use, like soups that will be pureed.</li> </ul>
<ul style="list-style-type: none"> <li>Soft cheese collects on top of the slice/grate disc.</li> </ul>	<ul style="list-style-type: none"> <li>The cheese was not cold enough. The pressure exerted on the pusher was too great.</li> </ul>	<ul style="list-style-type: none"> <li>Be sure soft cheeses are well chilled or place in freezer until knife inserted into cheese penetrates about 12mm.</li> <li>Remember food pusher is to be used as a guide; never exert hard pressure on the food pusher.</li> </ul>











## MINI CHEESE CAKES

Makes: 6

### Ingredients:

1 cup whole wheat biscuits (such as Granita)  
1 tsp mixed spices  
2 tbsp melted butter  
250g cream cheese  
3 tbsp castor sugar  
½ cup milk  
3 eggs  
½ cup light sour cream  
1 tsp vanilla essence

### Directions:

1. Preheat the oven to 160°C, and lightly grease flan tins or muffin tins.
2. To make the biscuit base, roughly break up the biscuits and place in the Food Processor bowl.
3. Add the mixed spice and process until biscuits are crumbed using the pulse button.
4. Pour in melted butter and stir with a wooden spoon until combined. Spread the base of the tins with the crumb mixture.
5. To make the filling, spoon the cream cheese into the Food Processor bowl. Add the sugar and milk and process on a low speed until just mixed. Add the eggs and process until well combined. Add the sour cream and vanilla and process until all ingredients are mixed thoroughly to a smooth consistency.
6. Pour the cream cheese filling over the biscuit bases and smooth the surface.
7. Bake in the oven for 40-45 minutes, or until golden and lightly firm to touch.
8. Turn off the heat and leave in the oven for another hour to prevent cracking.
9. Chill in the refrigerator until ready to serve.
10. Serve with berries and cream.

## FRENCH CREPES

Serves: 4

### Ingredients:

1 cup plain flour, sifted  
2 tsp castor sugar  
2 eggs  
½ cup milk  
½ cup water  
2 tsp butter, melted  
Fresh strawberries  
Castor sugar to taste

### Directions:

1. Combine flour and castor sugar in the Food Processor. Blend on low speed and gradually pour in combined milk, water and melted butter. Blend until ingredients are mixed together.
2. Transfer batter to a bowl and leave for at least 1 hour. Mixture will be quite thin.
3. Brush a non-stick fry pan with melted butter, add approx 2 tablespoons of the mixture and swirl around until base of pan is coated. Cook for 2 minutes or until golden brown then turn carefully flip with a plastic spatula and cook the second side.
4. Remove carefully and transfer to a warmed plate, cover with plastic film.
5. Continue to cook the remaining crepes as above and stack until required.
6. For the strawberry puree, roughly chop or slice strawberries and place in the small processor bowl with the sugar. Puree to preferred consistency.
7. Serve the crepes with strawberry puree and strawberries.

## SPINACH PESTO PIZZA

**Makes:** one 35cm pizza.

### Ingredients:

1 pizza base  
440g mozzarella cheese  
4 tomatoes, sliced  
70g parmesan cheese  
¼ cup loosely packed basil leaves  
Salt & pepper, to taste

### SPINACH PESTO

2 cups spinach leaves  
1 cup basil leaves  
½ cup parsley  
10g parmesan cheese  
½ cup pine nuts  
2 cloves garlic, minced  
1 tsp grated lemon peel  
¾ cup olive oil

### Directions:

1. Preheat the oven to 230°C.
2. Fit the large processor bowl with the chopping blade. Place all ingredients for the pesto in the bowl and process until smooth.
3. Grate mozzarella cheese using coarse grating disc and set aside. Repeat process to grate parmesan cheese.
4. Place the pizza base onto a lightly greased pizza pan.
5. Spread pesto evenly on pizza base leaving about 1.5cm border. Sprinkle mozzarella cheese evenly over pesto. Arrange tomato slices over cheese.
6. Sprinkle with Parmesan cheese and basil. Season to taste.
7. Bake in the oven for about 12 minutes, or until crust is browned and cheese is golden.

## STUFFED MUSHROOMS

Serves: 6

### Ingredients:

200g sausage meat  
12 large mushrooms  
1 large spring onion  
1 large clove garlic  
1 slice white bread  
2 tsp parsley, chopped  
2 tsp vegetable stock  
4 tsp melted butter  
½ cup parmesan cheese, grated

### Directions:

1. Preheat the oven to 175° C.
2. In a frypan, cook the sausage meat over a medium heat, stirring to break into bits.
3. Remove the stem from the mushrooms, being careful not to break mushroom caps. Set mushroom caps aside.
4. In the Food Processor bowl, place the spring onion and garlic, and process on low to chop. Add white bread and mushrooms stems and process for a few seconds to break into small pieces.
5. Add cooked sausage and process for several seconds. Stir in parsley and stock.
6. Melt the butter in a large bowl, and toss mushroom caps until coated. Arrange in single layer in shallow baking dish. Fill with the sausage mixture. Top with the parmesan cheese.
7. Bake for 15 minutes until hot and bubbly.
8. Serve with a dollop of sour cream.

## PIZZA DOUGH

**Makes:** 1 base, approx 35cm diameter

### Ingredients:

1¼ tsp active dry yeast

1⅓ cups warm water (40°C)

¼ tsp sugar

3½ to 3¾ cups unsifted plain flour

1 tsp salt

2 tbsp olive oil

### Directions:

1. Sprinkle yeast over water, add sugar and let stand for 5 minutes until yeast is dissolved.
2. Position dough blade in workbowl of Food Processor.
3. Add 3 cups flour, salt and olive oil. With processor running, gradually add yeast mixture down food chute. Add additional flour to make soft dough. Continue processing dough for 1 minute.
4. Transfer dough to lightly floured board. Shape into ball and cover with towel or large bowl. Let dough rest for 10 minutes.
5. On lightly floured board, knead several times until smooth and elastic; form into ball. Place in greased bowl, turning to grease the top. Cover and let rise at room temperature until doubled in bulk. (About 1 hour)
6. Punch dough down, and roll out to a circle approximately 35cm diameter.

## COLESLAW

**Makes:** about 6 cups

### **Ingredients:**

½ medium head cabbage, cut into wedges  
1 wedge purple cabbage  
2 medium carrots, peeled and trimmed  
1 small purple onion  
½ cup stuffed olives, coarsely chopped  
¾ cup mayonnaise  
3 tbsp red wine vinegar  
½ tsp celery seed  
Ground pepper, to taste

### **Directions:**

1. Using thin slicing blade, thinly slice cabbages.
2. Using the grating disc, grate the carrots and onion.
3. Place vegetables in a large bowl and add the olives.
4. In a smaller bowl, blend remaining ingredients.
5. Pour over cabbage mixture and toss to combine.
6. Cover and refrigerate at least 1 hour to allow flavours to blend.

## CREAMED BROCCOLI SOUP

Servings: 4

### Ingredients:

2½ cups chicken or vegetable stock  
2 medium potatoes, peeled and diced  
200g broccoli, cut into small pieces  
½ cup cream  
Salt & pepper to taste

### Directions:

1. Place broccoli and potatoes into a saucepan, cover with stock and cook on medium heat until vegetables are tender.
  2. Transfer vegetables and liquid into the Food Processor, reserving a few small sprigs of broccoli for garnish.
  3. At low speed, blend until coarsely chopped then increase speed and blend until smooth.
  4. Return the soup to the saucepan, stir in the cream and add salt and pepper to taste.
  5. Reheat gently, stirring occasionally, without allowing to boil.
- To serve, ladle into bowls, swirl a little cream into each and garnish with the small sprigs of reserved broccoli.

[www.russellhobbs.com.au](http://www.russellhobbs.com.au)

[www.russellhobbs.co.nz](http://www.russellhobbs.co.nz)

RUSSELL HOBBS and logo are Trade Marks of Spectrum Brands, Inc., or one of its subsidiaries. ©2016 Spectrum Brands, Inc.

Recipes are to be used in conjunction with the RHFPT1 Food Processor by Russell Hobbs. All rights reserved. No part of this publication may be reproduced, stored in a retrieval system or transmitted in any form or by any means, electronic, mechanical, photocopying, recording or otherwise, without prior permission of the copyright owner.

RHFPT1

2 YEAR WARRANTY

# FOOD PROCESSOR

